

# Designed for a code. Not adapted for one.



## STANDARD DRAWER PULL COLOR



## PEDIATRIC COLOR KIT



- > Advanced polymer construction, rounded corners and Microban antimicrobial product protection help maintain a cleaner cart to improve infection control.
- A. Lightweight polymer construction, ergonomic handle and proprietary 5th-wheel steering system assures maximum control in transit and maneuverability during a code.
- B. Tilt out side bins, top storage compartment and drawers provide simultaneous access to multiple stored products.
- C. Cord management and restraint system keeps cords neatly organized and protects equipment from accidental damage.
- D. Strapless defibrillator platform adjusts to accommodate various defibrillators.
- E. Swingarm positions defibrillator closer to the patient; clears top work area.
- F. Recessed top storage with a clear removable cover provides instant access to first line meds or airway equipment without impeding access to drawers.
- G. Convenience features include an extendable I.V. Pole, O<sub>2</sub> Tank Storage, Suction Pump Shelf, Glove Box Holder, Lockable Sharps Container, Hospital Grade Outlet Strip, Cord Management, Trays & Dividers.
- H. Full extension drawers have self-closing ball bearing slides to provide easy access to medications and supplies. (Drawer depths: 3", 6", 9", 12")
- I. Lock mechanism secures top compartment, drawers and side bins and can be sealed in segments or one seal secures all.
- J. Backboard can be mounted to the front or back of the cart.
- K. Two brake casters positioned in the front of the cart to provide stability.



Packages include cart and accessories.



Cat. No. **LECCRP2**  
Code Response Cart



Cat. No. **LECCRP3**  
Code Response Cart



Cat. No. **LECCRP4**  
Code Response Cart



Cat. No. **LECCRP5**  
Code Response Cart



Cat. No. **LECCRP7**  
Code Response Cart



Cat. No. **LECPEDS2**  
Code Response Cart

## Upgradeability.



Basic Cart with side bins and tank holder



Time.  
Budget.  
Needs.



Upgrade with defibrillator arm, storage bin and suction shelf



Time.  
Budget.  
Needs.



Upgrade again with drawers, trays & dividers

One of the best features about Lifeline is its upgradeability. Start with a basic model based on budget or current requirements and buy the confidence that it can change as your needs change.

Note: Model Numbers shown for carts with open storage below drawers do not include security mechanism for open space. Contact your SEK Medical Representative for a quotation with secure storage space.

Build a cart to your exact specifications.

**Code Response Preconfigured Carts**

Carts shown on the previous pages are configured with the components and accessories listed here.

**Accessories**

Cat. No.	Description	LECCRP2	LECCRP3	LECCRP4	LECCRP5	LECCRP6	LECCRP7	LECCRP8	LECPEDS1	LECPEDS2
FL120	Solid Bottom Shelf							X		
LEC143	Top Cavity Tray		X		X	X		X		
FL151	3" (76mm) Drawer Divider Tray with Dividers				1	2				7
FL159	6" (152mm) Drawer Divider Tray with Dividers				1	1				1
FL190	Label Holder Set of 10						X			
FL211	Side Bin (1) — Locking		3	3	3		4	3	2	4
FL221	Waste Basket 28 Quart & Holder	X				X			X	
LEC236	Glove Box Holder — Single (Mounts to Handle Side)				X				X	
LEC251	Lockable Sharps Container (Mounts to Handle S ide)	X				X				X
FL302	Cord Manager				X		X			X
LEC304	Adjustable Defibrillator Tray	X	X	X	X	X	X	X	X	X
FL305	Hospital Grade 6-Outlet Strip and Holder (120V)						X			X
LEC306	Suction Pump Shelf		X		X		X	X		X
LEC308	Backboard with Front Assembly Kit		X	X	X	X		X	X	
LEC309	Backboard with Back Assembly Kit	X					X			X
Included	Oxygen Tank Holder	X	X	X	X	X	X	X	X	X
FL315	I.V. Pole with Cart Mount	X	X	X	X	X	X	X	X	X
LEC319	Storage/Gel Bin		X				X	X		
LEC320	Plastic Security Seals 100 Pack	X	X	X	X	X	X	X	X	X
FL403	Individual Drawer Seal Lock Bar									X
LEC-PED8	Pediatric Code Response Drawer Kit								X	X

**Carts**

Cat. No.	Description	LECCRP2	LECCRP3	LECCRP4	LECCRP5	LECCRP6	LECCRP7	LECCRP8	LECPEDS1	LECPEDS2
LEC24P	39" (991mm) Cart	X	X					X		
LEC27P	42" (1067mm) Cart			X	X					
LEC30P	45" (1143mm) Cart					X	X		X	X

**Drawers, with Code Blue\* Drawer Pull**

Cat. No.	Description	LECCRP2	LECCRP3	LECCRP4	LECCRP5	LECCRP6	LECCRP7	LECCRP8	LECPEDS1	LECPEDS2
LEC103	3" (76mm) Drawer	1	2	2	3	4	2	2	7	7
LEC106	6" (152mm) Drawer	3	1	1	1	1	2	1	1	1
LEC109	9" (229mm) Drawer		1		1	1	1			
LEC112	12" (305mm) Drawer			1						

\*Multicolor Drawer Pulls are provided on Pediatric Carts



**5th wheel maneuverability.**

Lightweight polymer construction, ergonomic handle and proprietary 5th-wheel steering system assures maximum control in transit and maneuverability during a code.

## Build-a-Cart

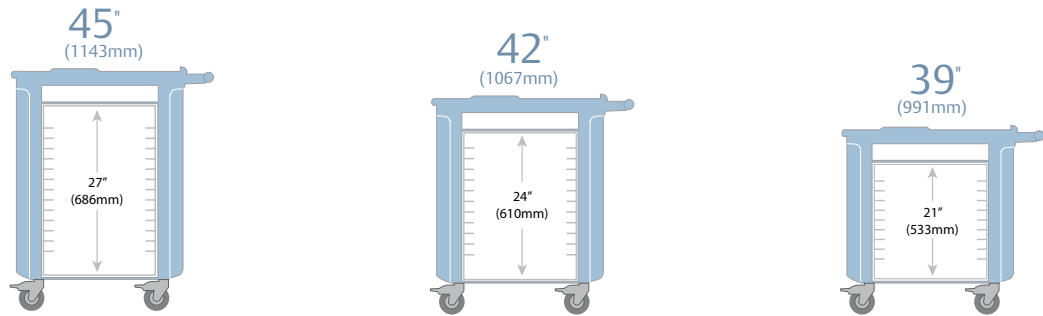

Cart Bodies without Drawers

Width/Length/Height (in.)	Width/Length/Height (mm)	Storage Space (in.) (mm)	Drawer Space (in.) (mm)	Steering Assist	Tank Holder	Cat. No.
22 <sup>5</sup> / <sub>8</sub> x 38 x 38 <sup>3</sup> / <sub>4</sub>	575 x 965 x 984	24 610	21 533	X	X	<b>LEC24P</b>
22 <sup>5</sup> / <sub>8</sub> x 38 x 42 <sup>1</sup> / <sub>8</sub>	575 x 965 x 1070	27 686	24 610	X	X	<b>LEC27P</b>
22 <sup>5</sup> / <sub>8</sub> x 38 x 45 <sup>1</sup> / <sub>2</sub>	575 x 965 x 1156	30 762	27 686	X	X	<b>LEC30P</b>

Note: Width includes optional backboard holders.



STANDARD DRAWER PULL COLOR CODE BLUE



PEDIATRIC DRAWER AND COLOR KIT

(Includes drawers, colored pulls and labels only)

## Additional Security

Description	Cat. No.
Individual Drawer Seal Lock Bar for LEC24P	<b>FL401<sup>F</sup></b>
Individual Drawer Seal Lock Bar for LEC27P	<b>FL402<sup>F</sup></b>
Individual Drawer Seal Lock Bar for LEC30P	<b>FL403<sup>F</sup></b>

<sup>F</sup>Must be factory installed prior to shipment.

## Drawer and Shelf

Description	Cat. No.
3" (76mm) Pull Out Shelf	<b>FL101</b>
3" (76mm) Drawer with Code Blue Pull	<b>LEC103</b>
6" (152mm) Drawer with Code Blue Pull	<b>LEC106</b>
9" (229mm) Drawer with Code Blue Pull	<b>LEC109</b>
12" (305mm) Drawer with Code Blue Pull	<b>LEC112</b>
Solid Bottom Shelf	<b>FL120</b>
Drawer Kit, Pediatric (7-3" Drawers and 1-6" Drawer)	<b>LEC-PED8*</b>

\*Inside Drawer Dimensions — 20<sup>1</sup>/<sub>4</sub>" (514mm) wide x 17" (432mm) deep; Heights: 2<sup>1</sup>/<sub>4</sub>" (70mm), 5<sup>1</sup>/<sub>4</sub>" (146mm), 8<sup>3</sup>/<sub>4</sub>" (222mm) 11<sup>3</sup>/<sub>4</sub>" (298mm).

\*\*Can only be ordered with a 45" cart.



LEC251

## Right (Handle) Side Accessories

Description	Cat. No.
Glove Box Holder — Single 4" x 10 <sup>1</sup> / <sub>8</sub> " x 6 <sup>3</sup> / <sub>8</sub> " (101 x 258 x 162mm)	<b>LEC236</b>
Lockable Sharps Container 4 <sup>3</sup> / <sub>4</sub> " x 13" x 19 <sup>7</sup> / <sub>8</sub> " (with Glove Box) x 11 <sup>3</sup> / <sub>8</sub> " H (without Glove Box) (121 x 330 x 505 or 302mm)	<b>LEC251</b>
Replacement Containers for LEC251 — 20 5 Quart Containers	<b>FL252</b>
Suction Pump Shelf 12 <sup>1</sup> / <sub>2</sub> " x 15 <sup>1</sup> / <sub>4</sub> " x 4 <sup>1</sup> / <sub>4</sub> " (320x384x108mm)	<b>LEC306</b>
Oxygen Tank Holder*	—

\*Included on all carts



LEC306